

PFANKUCH Feeder Head

Model ASB 175-/310-/380-/450-/650-K with Horizontal Delivery

Automatic separating, counting and feeding of flat products for further processing

Machine Concept

The technical well matured machine concept of PFANKUCH ASB feeder head systems is field proven for automated separation, counting and feeding of flat products in numerous application areas worldwide. ASB feeder heads operate on a top load bottom feed friction principle. Flexible, profiled and anti static feed belts separate the lowest product damage-free from the magazine pile into a standby position for a photo optical double and miss-feed control. Out of this position, the cycled feeding process is initiated by an electronic start sensor. Contra rotating stripper wheels prevent simultaneous feeding of following products.

The available variety of PFANKUCH ASB models offers different feeder width dimensions for processing product sizes up to 575 mm width (see technical data). The modular technical design also considers multiple possibilities for most exact product positionings according to customer demands. Furthermore the design allows easy and uncomplicated machine integration into existing customer machinery.

The horizontal delivery is height adjustable and helps to bridge the gap between feeder and product dispensing position in horizontal direction. There are different lengths for the horizontal delivery available (245, 505 and 620 mm).

Technical Machine Equipment

- Automated product processing up to 2 mm thickness (special option up to 8 mm)
- Variable speed adjustability from 0 up to 115 m /min.
- Photo optical, self adjusting double and miss-feed control (depending on product specifications)
- Magazine stack height up to 500 mm (depending on product specifications)
- Reproducible product size adjustments by scaling ensure uncomplicated and easy product change over
- Flexible pre-selection of product counting numbers
- Microprocessor controlled and user friendly machine operating panel with variable positioning choice
- external start signal processing e.g. by light barrier, speed synchronisation by incremental encoder (optional)

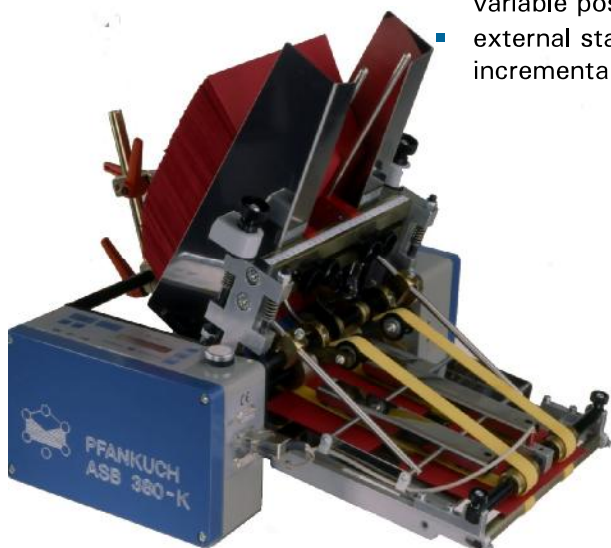

Advantages at a Glance

- Compact construction designed for heavy duty applications
- Secure and damage-free product separation and feeding – even for most sensitive products
- Highest cycle speeds and reliable operation security ensure most efficient productivity, efficiency and profitability
- The modular machine design offers various choices for meeting specific customer demands in technical machine layout
- Easy and uncomplicated machine integration
- Innovative microprocessor based control board

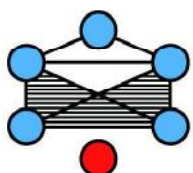

PFANKUCH

PFANKUCH MASCHINEN GMBH

Kurt-Fischer-Str. 23b

D – 22926 Ahrensburg / Germany

Tel. + 49 (0) 4102-47810

Fax + 49 (0) 4102-478180

www.pfankuch.com

info@pfankuch.com

Technical Data

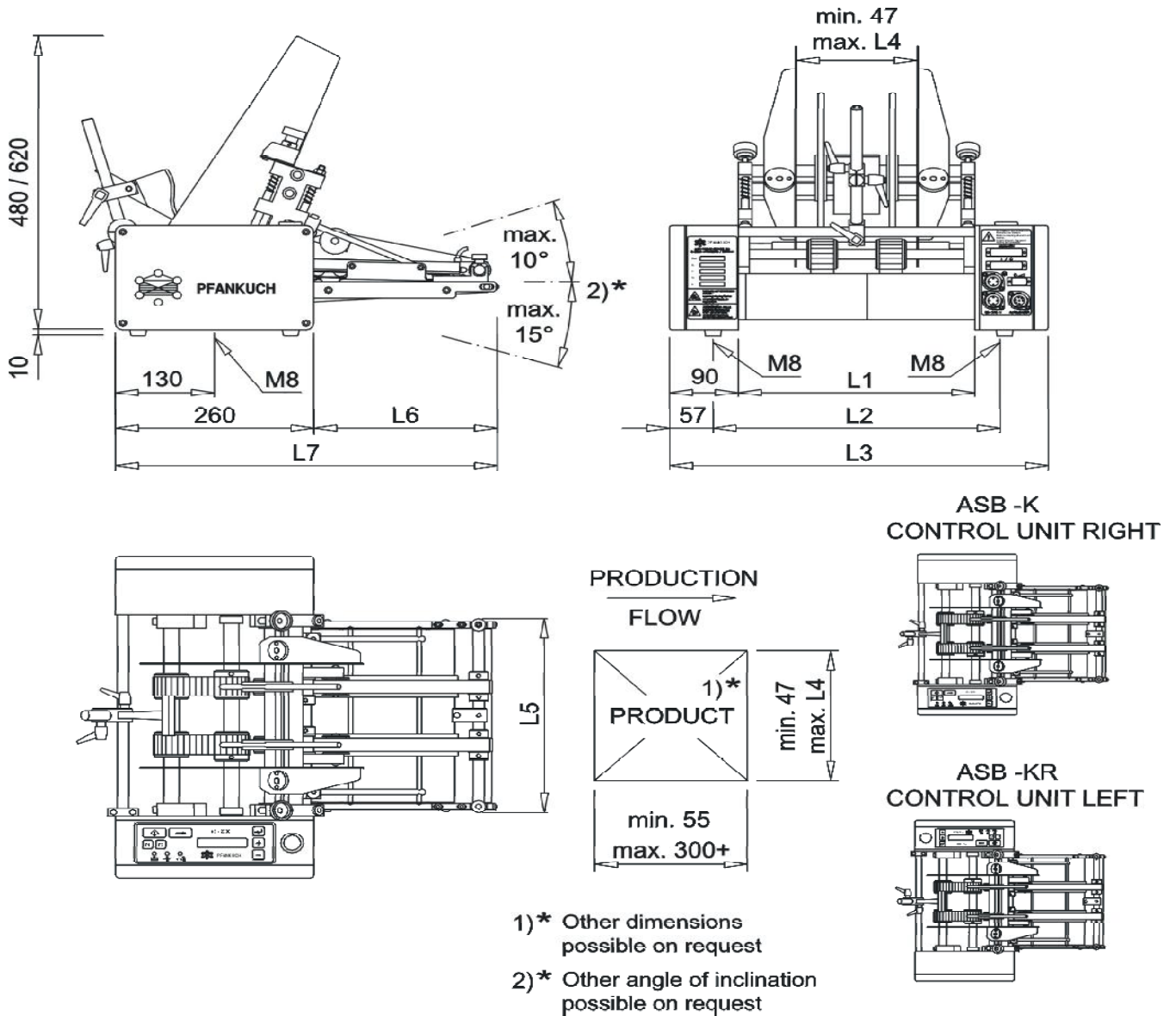

Feeder Model	L1 (mm)	L2 (mm)	L3 (mm)	L4 (mm)	L5 (mm)	Max. Speed (depending on product specs.)	Weight (net Kg)
ASB 175-KL/ -KR	175	241	361	105	165	115 m/min.	24
ASB 310-KL/ -KR	310	376	496	240	300	115 m/min.	29
ASB 380-KL/ -KR	380	446	566	310	370	115 m/min.	36
ASB 450-KL/ -KR	450	516	636	380	440	115 m/min.	43
ASB 650-KL/ -KR	650	716	836	575	640	115 m/min.	63

Horizontal Delivery	L6 (mm)	L7 (mm)
Type 150	245	505
Type 380	505	765
Type 500	620	880

Multi Voltage : 90 – 240 V, max. 4 A, 50-60 HZ, 0,4 KW
 Drive : Servo Motor
 Protective System : Standard: IP43 (Special Option: IP 63)

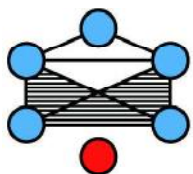

PFANKUCH

PFANKUCH MASCHINEN GMBH
 Kurt-Fischer-Str. 23b
 D – 22926 Ahrensburg / Germany
 Tel. +49 (0) 4102-47810
 Fax +49 (0) 4102-478180
 www.pfankuch.com
 info@pfankuch.com